

DA

sommersibili per drenaggio

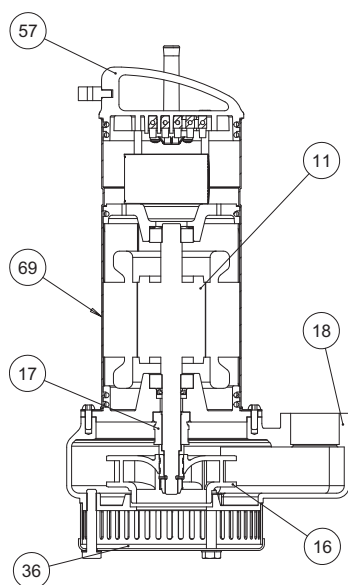

NOMENCLATURA PARTI DI RICAMBIO
SPARE PARTS LIST
NOMENCLATURE PIECES DE RECHANGE
NOMENCLATURA REPUESTOS



- 11 Albero con rotore – Pump shaft + rotor
Arbre + rotor – Eje rotor
- 16 Girante – Impeller
Turbine – Impulsor
- 17 Tenuta meccanica – Mechanical seal
Garniture mécanique – Cierre mecánico
- 18 Corpo pompa – Pump body
Corp de pompe – Cuerpo bomba
- 57 Manico – Handle
Poignée – Manejar
- 69 Camicia – Cover
Chemise – Camisa
- 36 Filtro - Filter
Filtre - Filtro

ELETTROPOMPE SOMMERGIBILI PER DRENAGGIO

Le elettropompe sommergibili della serie DA sono particolarmente adatte al sollevamento di liquidi puliti o parzialmente sporchi, anche con corpi solidi in sospensione con un Ø massimo di 4 mm, non esplosivi e chimicamente non aggressivi per i materiali della pompa, senza parti abrasive. Temperatura max. 35 °C. (CEI EN 60335-2-41).

CARATTERISTICHE COSTRUTTIVE

- Corpo motore: acciaio inox Aisi 304
- Corpo pompa: ghisa G20 con trattamento anticorrosione
- Girante: Tecnopolimero
- Albero pompa: acciaio inox Aisi 420
- Tenuta meccanica lato pompa: carbone - ceramica
- Tenuta meccanica lato motore: a labbro in NBR
- Cavo di alimentazione: 10 m HO7RN-F

MOTORE

- Motore ad induzione a due poli, riavvolgibile, con protezione IP68, isolamento classe F.
- Alimentazione monofase con motoprotettore incorporato e condensatore permanentemente inserito.
- Alimentazione trifase con protezione obbligatoria a cura dell'utente.
- Servizio continuo se completamente sommersa.

A RICHIESTA:

- Versione monofase automatica con galleggiante flottante (AUT).

ÉLECTROPOMPES SUBMERSIBLES POUR EAUX USÉES

Les électropompes submersibles de la série DA sont particulièrement adaptées au relèvement de liquides propres ou partiellement sales, même avec des corps solides en suspension avec un Ø maximum de 4 mm, non explosifs et chimiquement non agressifs pour les matériaux de la pompe, sans parties abrasives. Température max. 35 °C. (CEI EN 60335-2-41).

CARACTERISTIQUES DE CONSTRUCTION

- Corps de moteur: acier inox Aisi 304
- Corps de pompe : En fonte G20 avec traitement anti-corrosion
- Turbine: Technopolymère
- Abre de pompe: acier inox Aisi 420
- Garniture mécanique partie pompe: Carbone dur - Céramique
- Garniture mécanique partie moteur: à lèvre en élastomère
- Câble d'alimentation: 10 m HO7RN-F

MOTOR

- Moteur à induction à deux pôles rebobinable, refroidi par le liquide pompé, protection IP68, classe d'isolation F.
- Le modèles monophasé son avec protection thermique et condensateur connecté en permanence
- Pour les modèles triphasés, la protection est à la charge de l'utilisateur. A recommandé l'équipement conformément à la réglementation
- Service S1 (s'il est complètement immergé)

SUR DEMANDE:

- Version Monophasée avec flotteur automatique

SUBMERSIBLE ELECTRIC WASTEWATER PUMPS

The submersible draining electric pump series DA have been designed for pumping clear or slightly dirty liquids, non-explosive or chemically aggressive for the pump's materials, either containing suspended solids max Ø 4 mm, without abrasives parts. Temperatures not higher 35 °C (CEI EN 60335-2-41).

TECHNICAL FEATURES

- Motor body: stainless steel Aisi 304
- Pump body: cast iron G20 with anti-corrosive coating
- Impeller: Techno-polymer
- Pump shaft: stainless steel Aisi 420
- Pump's side mechanical seal: carbon - ceramics
- Motor's side seal: lip ring in NBR
- Feeding cable: 10 m HO7RN-F

MOTOR

- Two poles induction rewindable motor with protection IP 68, class F insulation.
- Single-phase feeding with incorporated motor protector and capacitor permanently connected.
- Three-phase feeding with compulsory protection to be provided by the user.
- Continuous duty if completely submerged.

ON REQUEST:

- Single-phase automatic version with float switch (AUT).

ELECTROBOMBAS SUMERGIBLES PARA AGUAS RESIDUALES

Las electrobombas sumergibles de la serie DA son especialmente adecuadas para la elevación de líquidos limpios o parcialmente sucios, incluso con cuerpos sólidos en suspensión con un Ø máximo de 4 mm, que no sean explosivos ni químicamente agresivos para los materiales de la bomba, sin partes abrasivas. Temperatura max. 35 °C. (CEI EN 60335-2-41).

CARACTERÍSTICAS DE CONSTRUCCIÓN

- Cuerpo de motor: de acero Inox AISI304
- Cuerpo de bomba: Fundición gris G20 con tratamiento contra-corrosión
- Rodete: Tecnopolimero
- Eje de la bomba: de acero Inox Aisi 420
- Cierre mecánico lado bombas: cerámica-grafito
- Cierre mecánico lado motor: anillo de cierre en NBR
- Cable de alimentación :10 mt HO7RN-F
- Máxima inmersión :5 mt

MOTOR

- Motor a inducción de dos polos rebobinables, enfriado por el líquido bombeado, protección IP68, aislamiento de clase F.
- Para los modelos monofásicos, protección térmica y condensador incorporado
- Para los modelos trifásicos de la protección se encarga el usuario y el equipo recomendado de acuerdo con las normas
- Funcionamiento S1 (si es completamente sumergida)

BAJO DEMANDA:

- Versión Monofásico con interruptor de nivel automático (AUT)

50 Hz

TIPO TYPE		Potenza nominale Nominal power		Potenza assorbita Input power [W]		Condensatore Capacitor 450 V max	Corrente assorbita Input current [A]		Portata - Capacity										
Monofase Single-phase	Trifase Three-phase	kW	HP	a	b		[μF]	1-230V	3-400V	Q [m3/h]	0	3	6	9	12	15	18	21	
a	b								Prevalenza (m C.A.) Total head (m W.C.)										
DA 100 M	-	0,74	1	1040	-	20	4,7	-	H [m]	11,6	11,0	10,9	10,0	9,1	7,5	6,0			
DA 120 M	DA 120 T	0,88	1,2	1390	1460	25	6,2	3,8	H [m]	13,9	13,5	13,3	12,8	11,0	9,5	8,0	6,5		

a) - Monofase 230 V b) - Trifase 230/400 V

60 Hz

TIPO TYPE		Potenza nominale Nominal power		Potenza assorbita Input power [W]		Condensatore Capacitor 450 V max	Corrente assorbita Input current [A]		Portata - Capacity										
Monofase Single-phase	Trifase Three-phase	kW	HP	a	b		[μF]	1-220V	3-380V	Q [m3/h]	0	3	6	9	12	15	18	21	
a	b								Prevalenza (m C.A.) Total head (m W.C.)										
DA 100 M	-	0,74	1	1040	-	20	4,7	-	H [m]	11,0	10,5	10,4	9,5	8,6	7,1	5,7			
DA 120 M	DA 120 T	0,88	1,2	1390	1460	25	6,2	2,7	H [m]	13,2	12,8	12,6	12,2	10,5	9,0	7,6	6,2		

a) - Monofase 115/220 V b) - Trifase 220/380 V

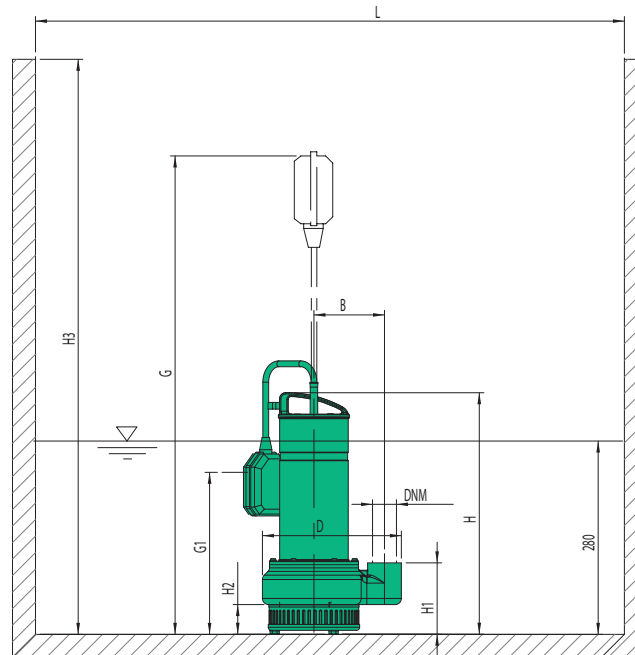

TIPO TYPE	DIMENSIONI [mm] DIMENSIONS [mm]											IMBALLO [mm] PACKING [mm]			PESO WEIGHT [kg]
	H	H1	H2	H3	B	D	F	G	G1	L	DNM	A	L	P	
DA 100	400	120	50	700	120	230	4	/	/	600X600	1" 1/4	290	610	250	14,4
DA 100 AUT	400	120	50	700	120	230	4	500	200	600X600	1" 1/4	290	610	250	14,8
DA 120	400	120	50	700	120	230	4	/	/	600X600	1" 1/4	290	610	250	15,6
DA 120 AUT	400	120	50	700	120	230	4	500	200	600X600	1" 1/4	290	610	250	16

$\text{min}^{-1} \sim 2900$

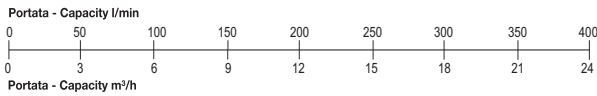
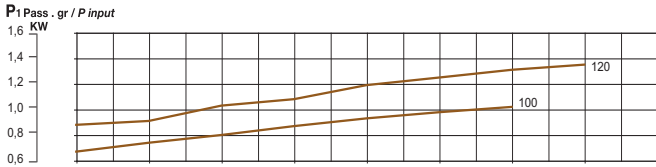
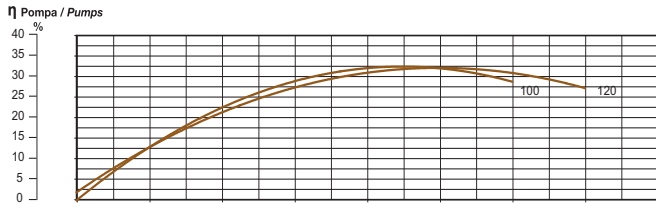
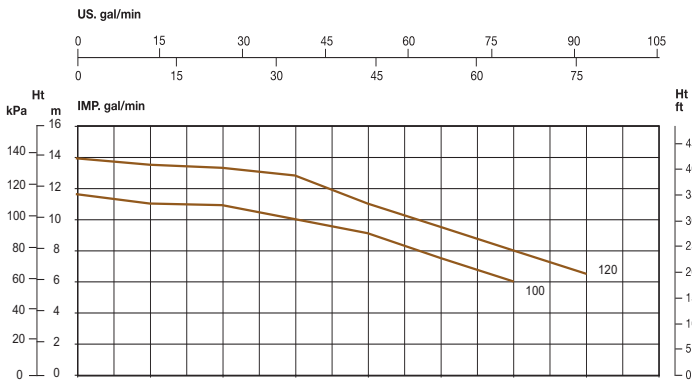

$\text{min}^{-1} \sim 3400$

