

Materials Table

No.	Part	Material	No.	Part	Material
1	Hose coupling	Cast iron	9	Cable	
2	Thermal protector		10	Bearing	
3	Upper cover	Cast iron	11	Rotor	
4	Motor cover	Cast iron	12	Stator	
5	Oil seal		13	Bearing	
6	Mechanical seal	Sic-Sic/Carbon-Sic (≤ 2.2 kW) Sic-Sic/Sic-Sic (≥ 3.7 kW)	14	Impeller	High chrome alloy
7	Strainer	Steel	15	Pump body	Cast iron
8	Handle	Steel	16	Inlet plate	Ductile iron

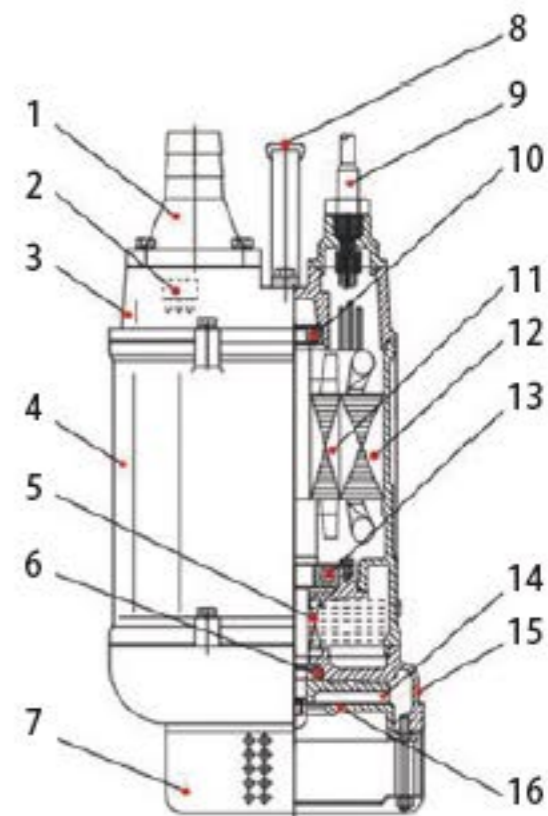

Package Information

Model	N.W (kg)	G.W (kg)	L (mm)	W (mm)	H (mm)	Quantity (PCS/20' TEU)
KBZ47.5	105	114	805	365	390	215
KBZ411	130	140	895	415	440	160
KBZ415	142	153	895	415	440	160
KBZ67.5	106	114	835	365	390	205
KBZ611	133	143	855	415	440	160
KBZ615	145	156	895	415	440	160

