

SUCTION FLOW ZONE DESIGN REFERENCE FOR SUBMERSIBLE AXIAL PUMP

Several problems might arise if the insufficient shape and dimensions of the suction flow zone are decided at the design stage and from the hydro-dynamical point of view. Problems such as: eddy current of the surface water, air mixing with the water, heavy turbulence of water flow and the formation of stagnant water. In order to prevent or to reduce these causes, there are several things that need to be considered:

- The liquid of suction flow speed should be kept constant (flow speed 0.3~0.5m/s).
- Suction flow zone of water depth and floor slop variation of slope angle should be 30°~45°.
- Suction flow zone should fill up with concrete.
- In two pump operations, eddy current protection wall must be installed in the suction zone.
- In a two pump operation, any sudden obstacles at the suction flow zone must be avoided and maximum divergent angle must not exceed 20°.

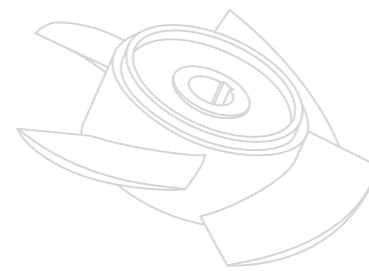
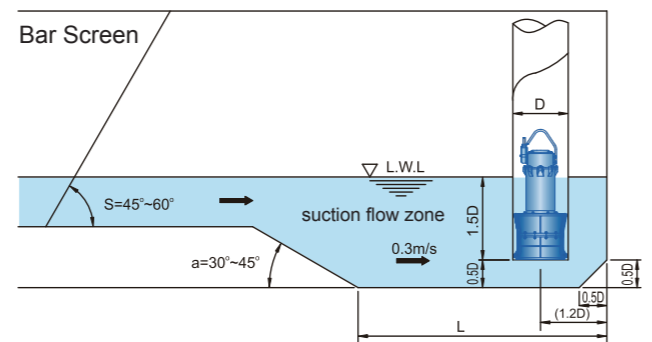
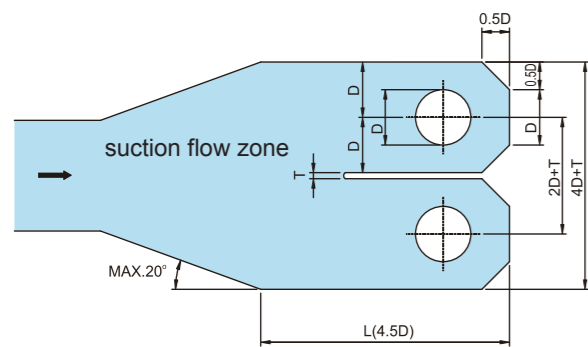
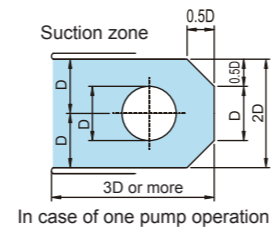

LA 50Hz & 60Hz
SERIES
 SUBMERSIBLE AXIAL PUMP

Professionalism • Innovation • Service • Commitment
HCP PUMP MANUFACTURER CO., LTD.
www.hcppump.com.tw



Distributor:

DLAEN0-1705

We reserve the right to alter specifications of product at any time without giving prior notice.



LA-2250/2260
(Well type)



LA-2250/2260
(Stand type)



LA-2875/28100
(Well type)



LA-2875/28100
(Stand type)

LA

FEATURE

- High efficiency motor connects directly to the impeller for the best energy savings.
- Strong material and construction, double mechanical seal, epoxy resin cable entry, IP68 waterproof.
- Shaft and impeller has been precisely balanced for a quiet and long life performance.
- Standard protection is miniature thermal protector and mechanical seal leakage detector. Optional protection devices available.
- The 3D computerized impeller and vanes conductive design, creates a higher pump efficiency.
- Sacrificial Anode : Sacrificial Anodes are highly active metals that are used to prevent a less active material surface from corroding. Sacrificial Anode reduces the rusting corrosion in sea water and increase the lifetime of the pump.



Axial flow impeller



Sacrificial Anode

SUBMERSIBLE AXIAL PUMP STATION ADVANTAGES

- Simple design and construction for pump station.
- Frugal space makes it easier for installing and maintaining.
- Reduced expense in the pump station construction and installation.

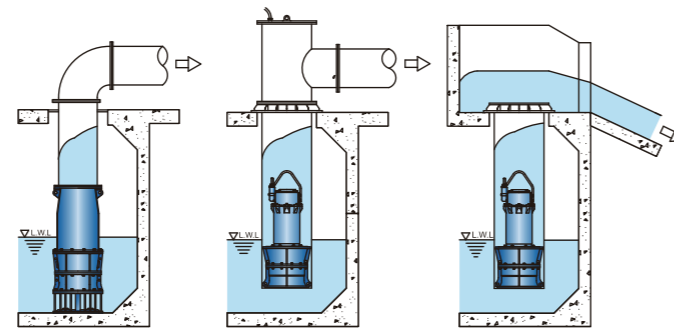

Stand type
(pipe connect)

Well type
(pipe connect)

Well type
(open flow)

APPLICATIONS

- Water supply or drainage for industrial.
- Water supply for cooling in the power plant.
- Used for large volume dewatering.
- Large scale aquaculture farming.
- Flooding Control.
- Others: Extraction of water from dock and river.

PROTECTOR DESCRIPTION (Optional)

- The Miniature Thermal Sesnsor (MTS) is mounted on the motor winding. The MTS sends a signal to the control box when the motor overheats. Consequently, the power supply is cut off, which prevents the pump from overload, overheating, etc.
- The Moisture Sensor (MS) is installed in the mechanical seal chamber, motor housing (optional) and the wiring chamber (optional). The MS detects moisture and sends a signal to the control box to prevent the pump from water leakage.
- The Bearing Thermal Sensor (BTS) is installed around the bearing. The BTS sends a signal to the control box when the bearing overheats to prevent the pump from overload, due to a damaged bearing.

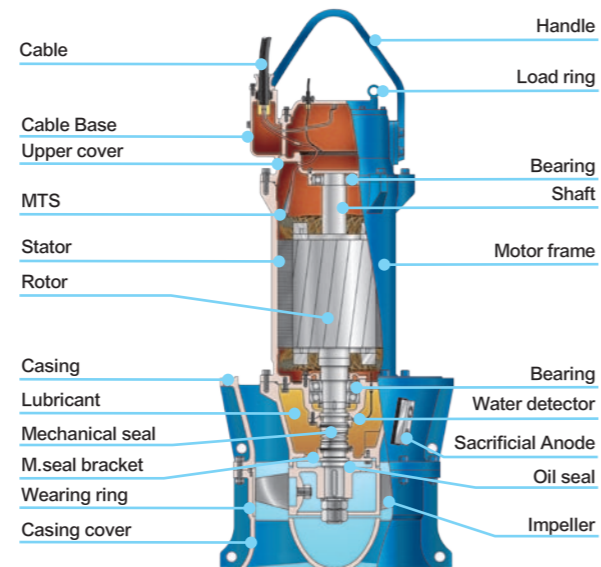

PERFORMANCE CURVES

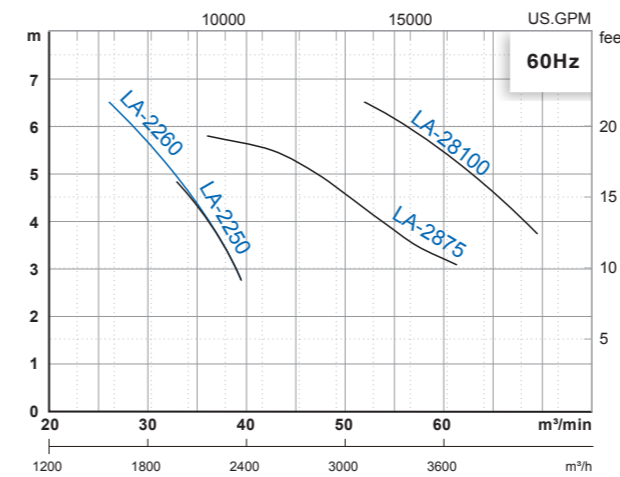
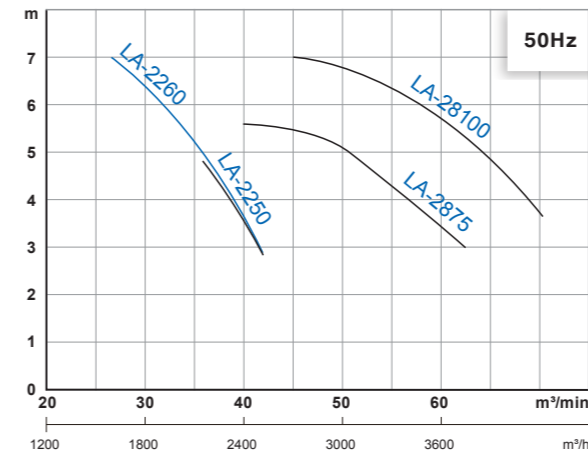

SPECIFICATIONS

Item	Description
Limits of Use	Liquid Temp. 0-40°C (32-104°F)
	Applications Wastewater • Industry drainage • Agriculture irrigation • Aquaculture water
Type	Frequency 50Hz / 60Hz
	Motor 50Hz/8P (750RPM: LA2250/2260) • 50Hz/10P (600RPM: LA2875/28100) • 60Hz/10P (720RPM: LA2250/2260) • 60Hz/12P (600RPM: LA2875/28100) • Dry Motor
	Insulation Class F (155°C)
	Protection IP68
	Protector MTS (Motor Thermal Sensor) • (MS)Moisture Sensor
	Bearing Ball Type
	M.seal Double M.seals
Material	Impeller Axial
	Upper Cover FC200
	Motor Frame FC200
	Shaft End SUS420J2
	M.seal SiC/SiC & SiC/SiC
	Casing FC200
	Impeller SCS13
	Cable VCT or PNCT or H07RN-F
Wearing ring SCS13(50-60HP) • ALBC3(75-100HP)	
Base stand / Outer cover SS400 (Stand type)	
Optional	Discharge and flange can be made to custom specification.

PRODUCT NOMENCLATURE

LA - 22 50
Type Discharge HP
inch

PERFORMANCE SPECS.

50Hz	Model	Output HP(kW)	Discharge Inch(mm)	Phase Ø	Start Method	Head (m)	Standard		Well type			Stand type		
							m³/min	m³/h	Dimensions mm		Weight kg	Dimensions mm		Weight kg
									A	B		A	B	
	LA-2250	50(37)	22"(550)	3	S-D	4	38	2280	803	1380	755	803	1960	1130
	LA-2260	60(45)	22"(550)	3	S-D	6	31	1800	803	1380	755	803	1960	1130
	LA-2875	75(55)	28"(700)	3	S-D	3.5	60	3600	870	2150	1530	930	2720	2060
	LA-28100	100(75)	28"(700)	3	S-D	5	60	3600	870	2150	1600	930	2720	2130

60Hz	Model	Output HP(kW)	Discharge Inch(mm)	Phase Ø	Start Method	Head (m)	Standard		Standard			Stand type		
							m³/min	ft-GPM	Dimensions mm		Weight kg(lb)	Dimensions mm		Weight kg(lb)
									A	B		A	B	
	LA-2250	50(37)	22"(550)	3	S-D	4-36	13-9510	803	1380	755 (1664)	803	1960	1130 (2491)	
	LA-2260	60(45)	22"(550)	3	S-D	6-28	20-7400	803	1380	755 (1664)	803	1960	1130 (2491)	
	LA-2875	75(55)	28"(700)	3	S-D	3.5-60	12-15850	870	2150	1530 (3373)	930	2720	2060 (4543)	
	LA-28100	100(75)	28"(700)	3	S-D	5-60	16-15850	870	2150	1600 (3527)	930	2720	2130 (4696)	

