



www.pumps.com.tw

J-200

Booster Pump

Liquid temperature: 0 °C to 80 °C / +32 °F to +176 °F
HP range: 1/4 HP / 200 W
pH: 6 to 8
Protection class: IP54



HUNG PUMP GROUP

Home Booster Pump



Better Cooling

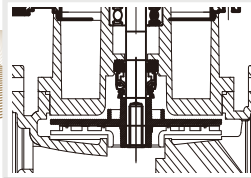

Pump casing design can ensure of the bearings' longevity & long time operation.



Impeller

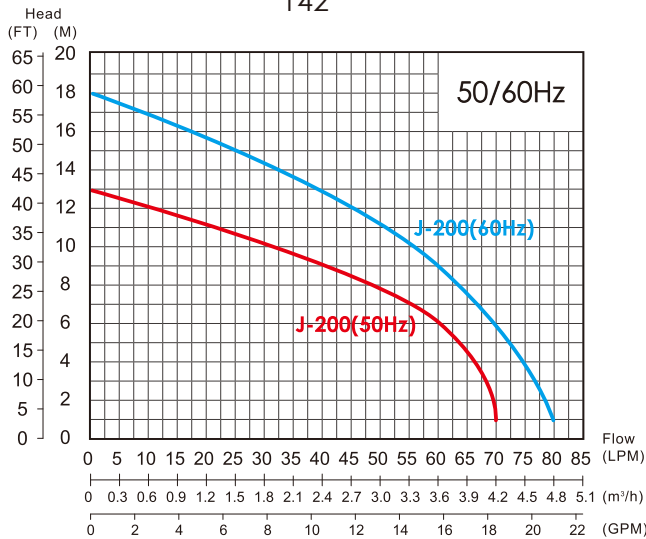
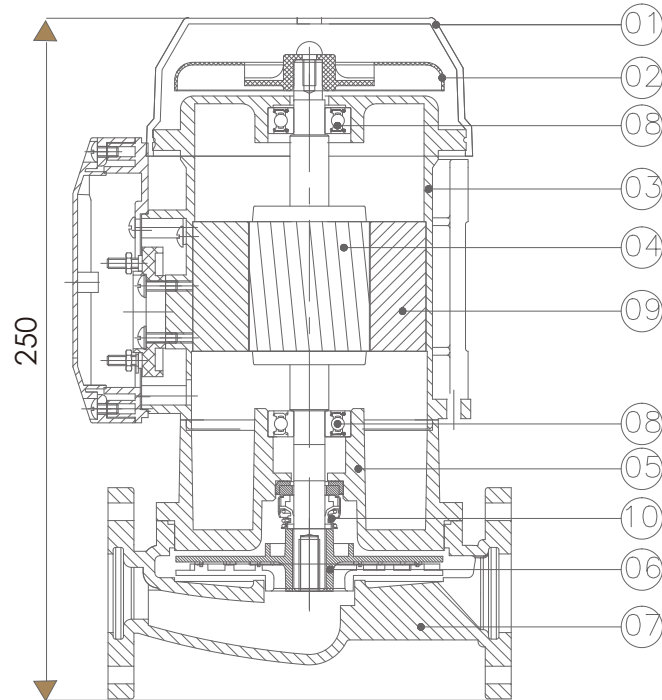
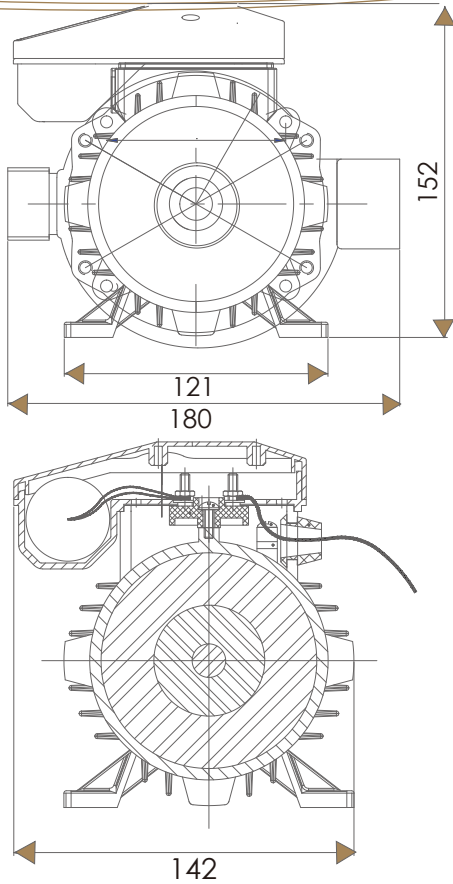

Construction(J-200)		
No.	Description	Material
1	Fan Cover	PP
2	Fan	PP
3	Motor Housing	ADC12
4	Rotor / Shaft	SUS410
5	Seal Plate	FC200
6	Impeller	NYLON+GF
7	Pump Casing	FC200
8	Upper & Lower Bearings	CNM 5K
9	Stator / Coil	C60
10	Mechanical Seal	CA/CE

Specification

Hz	Model No.	Power		Outlet		Pass solid (mm)	Max Flow (LPM)	LPM Flow @ Head					Max Head(M)	Dimension		Weight Kg
		HP	W	mm	inch			1.5M	3M	6M	9M	12M		L x W x H(mm)		
50	J-200	1/4	200	25	1"	N/A	70	69	68	60	40	10	13	250 x 180 x 152	7.1	
60							80	79	77	70	60	45	18			